

SCALING MODE SHAPES OBTAINED FROM OPERATING DATA

Brian Schwarz & Mark Richardson
 Vibrant Technology, Inc.
 Jamestown, California

ABSTRACT

A set of scaled mode shapes is a complete representation of the linear dynamic properties of a structure. They can be used for a variety of different analyses, including structural modifications, forced response simulations, excitation force calculations from measured responses, and FRF synthesis for comparison with experimental data.

When mode shapes are obtained experimentally from operating data, they are not properly scaled to preserve the mass & elastic properties of the structure. By operating data, we mean that only structural responses were measured. Excitation forces were not measured.

In this paper, we review the traditional methods for scaling experimental mode shapes using FRFs, and also introduce two new methods that don't require FRF measurement. The new methods combine a search algorithm with the SDM (Structural Dynamics Modification or eigenvalue modification) algorithm to perform a series of structural modifications until proper scaling of the mode shapes is achieved.

Details of the methods and examples of their use are included.

INTRODUCTION

Mode shapes are called "*shapes*" because they are unique in shape, but not in value. That is, the mode shape vector $\{\mathbf{u}_k\}$ for each mode(\mathbf{k}) does not have unique values,

$\{\mathbf{u}_k\}$ = DOFs-dimensional mode shape vector for the mode(\mathbf{k}).

DOFs = number of DOFs of the mode shape or structure model.

Each mode shape can be arbitrarily scaled to any set of values, but the relationship of one shape component to any other is unique. The "*shape*" of $\{\mathbf{u}_k\}$ is unique, but its values are not. A mode shape is also called an *eigenvector* for the same reason.

In order to preserve the mass & elastic properties of a structure using its mode shapes, they must be scaled in a particular manner. Properly scaled mode shapes can be used for different analyses, including structural modifications, forced response simulations, excitation force calculations from

measured responses, and frequency response function (FRF) synthesis for comparison with experimental data

Modal Mass Matrix

The mode shapes of a finite element model are defined in a manner which "simultaneously diagonalizes" both the mass and the stiffness matrix. This is the so-called orthogonality property.

When the mass matrix is post-multiplied by the mode shape matrix and pre-multiplied by its transpose, the result is a diagonal matrix, shown in equation (1). *This is a definition of modal mass.*

$$[\phi]^t [M] [\phi] = \begin{bmatrix} \dots & \mathbf{m} & \dots \end{bmatrix} = \begin{bmatrix} \dots & \mathbf{1} & \dots \\ \mathbf{A} \boldsymbol{\omega} & & \end{bmatrix} \quad (1)$$

where,

$[M]$ = mass matrix (DOFs by DOFs).

$[\phi] = [\{\mathbf{u}_1\} \{\mathbf{u}_2\} \dots \{\mathbf{u}_m\}]$ = mode shape matrix (DOFs by Modes).

t – denotes the transpose.

$\begin{bmatrix} \dots & \mathbf{m} & \dots \end{bmatrix} = \begin{bmatrix} \dots & \mathbf{1} & \dots \\ \mathbf{A} \boldsymbol{\omega} & & \end{bmatrix}$ = modal mass matrix (Modes by Modes).

Modes = number of modes in the model.

The modal mass of each mode(\mathbf{k}) is a diagonal element of the modal mass matrix,

Modal mass:
$$\mathbf{m}_k = \frac{1}{\mathbf{A}_k \boldsymbol{\omega}_k} \quad \mathbf{k}=1, \dots, \text{Modes} \quad (2)$$

$\boldsymbol{\omega}_k$ = damped natural frequency of mode(\mathbf{k}).

\mathbf{A}_k = scaling constant for mode(\mathbf{k}).

Equation (2) indicates that modal masses are indeed arbitrary, and can also be written in terms of the modal frequency $\boldsymbol{\omega}_k$ and a scaling constant \mathbf{A}_k (See [2] & [3] for details of this definition).

Scaling Mode Shapes to Unit Modal Masses

One of the common ways to scale mode shapes is to scale them so that the modal masses are one (unity). This is called *unit modal mass* (UMM) scaling. When a mass matrix $[M]$ is available, the mode vectors would simply be scaled such that when the triple product $[\phi]^t [M] [\phi]$ is formed, the resulting modal mass matrix would equal an *identity matrix*.

However, when mode shapes are obtained from experimental measurements, no mass matrix is available for scaling them. Furthermore, when mode shapes are obtained from operating data, i.e. no excitation forces are measured, traditional scaling methods cannot be used either.

First, we will review the traditional scaling methods which rely on FRF measurements (where the excitation forces are measured), and then introduce two new methods that don't require FRF measurements.

SCALING MODE SHAPES USING FRFS

Traditional UMM mode shape scaling requires either the measurement of a Driving Point FRF, or a Triangular Measurement which involves three FRFs.

Experimental mode shapes are UMM scaled by using the relationship between residues and mode shapes [3].

$$[r(k)] = A_k \{u_k\} \{u_k\}^t \quad k=1, \dots, \text{Modes} \quad (3)$$

where,

$$[r(k)] = \text{residue matrix for mode}(k), \text{ (DOFs by DOFs)}$$

Residues are the constant numerators of the transfer function matrix when it is written in partial fraction form as,

$$[H(s)] = \sum_{k=1}^m \frac{[r(k)]}{2j(s-p_k)} - \frac{[r(k)]^*}{2j(s-p_k^*)} \quad (4)$$

where:

$$p_k = -\sigma_k + j\omega_k = \text{pole location for mode}(k).$$

$$\omega_k = \text{damped natural frequency of mode}(k).$$

$$\sigma_k = \text{damping coefficient of mode}(k).$$

* -denotes the complex conjugate.

$$[H(s)] = \text{transfer function matrix (DOFs by DOFs)}$$

Experimental FRFs are merely values of the transfer functions measured along the $j\omega$ -axis in the S-plane [4].

Equation (3) shows that each residue matrix $[r(k)]$ is formed by multiplying each mode shape $\{u_k\}$ by its own transpose. This causes *every row and column* of the residue

matrix to contain the mode shape, multiplied by a different shape component. This unique *outer product* is why experimental mode shapes can be obtained by measuring *just one row or column* of the transfer function matrix.

Each element of the residue matrix then, is the product of two mode shape components (u_{ik} & u_{jk}) and the scaling constant A_k ,

$$r_{ij}(k) = A_k u_{ik} u_{jk} \quad k=1, \dots, \text{Modes} \quad (5)$$

Residues have unique values, and therefore have engineering units associated with them.

Transfer functions for mechanical structures typically have units of (motion / force), and the denominators have units of Hz or (radians/second). Therefore, residues have units of (motion / force-second).

Equation (3) can be written for the j^{th} column (or row) of the residue matrix and for mode(k) as,

$$\left\{ \begin{matrix} r_{1j}(k) \\ r_{2j}(k) \\ \cdot \\ \cdot \\ r_{jj}(k) \\ \cdot \\ r_{nj}(k) \end{matrix} \right\} = A_k \left\{ \begin{matrix} u_{1k} u_{jk} \\ u_{2k} u_{jk} \\ \cdot \\ \cdot \\ (u_{jk})^2 \\ \cdot \\ u_{nk} u_{jk} \end{matrix} \right\} = A_k u_{jk} \left\{ \begin{matrix} u_{1k} \\ u_{2k} \\ \cdot \\ \cdot \\ u_{jk} \\ \cdot \\ u_{nk} \end{matrix} \right\} \quad (6)$$

Unique
Variable

where,

$$k=1, \dots, \text{Modes}$$

$$n = \text{DOFs} = \text{number of DOFs of the mode shape}.$$

The importance of this relationship is that *residues are unique in value* and reflect the unique physical properties of the structure, while the *mode shapes aren't unique in value* and can therefore be scaled in any manner desired.

The scaling constant A_k must always be chosen so that equation (6) remains valid. The value of A_k can be chosen first, and the mode shapes scaled accordingly, or the mode shapes can be scaled first and A_k calculated so that equation (6) is still satisfied.

In order to obtain UMM mode shapes, we simply set the modal mass equal to one (1) and solve equation (6) for A_k .

So, for UMM scaling,

$$\mathbf{A}_k = \frac{1}{\omega_k} \quad \mathbf{k}=1, \dots, \text{Modes} \quad (7)$$

Driving Point Measurement

UMM mode shape vectors are then obtained from the \mathbf{j}^{th} column (or row) of the residue matrix by substituting equation (7) into equation (6),

$$\begin{Bmatrix} \mathbf{u}_{1k} \\ \mathbf{u}_{2k} \\ \cdot \\ \cdot \\ \mathbf{u}_{nk} \end{Bmatrix} = \frac{1}{\mathbf{A}_k \mathbf{u}_{jk}} \begin{Bmatrix} \mathbf{r}_{1j}(\mathbf{k}) \\ \mathbf{r}_{2j}(\mathbf{k}) \\ \cdot \\ \cdot \\ \mathbf{r}_{nj}(\mathbf{k}) \end{Bmatrix} = \sqrt{\frac{\omega_k}{\mathbf{r}_{jj}(\mathbf{k})}} \begin{Bmatrix} \mathbf{r}_{1j}(\mathbf{k}) \\ \mathbf{r}_{2j}(\mathbf{k}) \\ \cdot \\ \cdot \\ \mathbf{r}_{nj}(\mathbf{k}) \end{Bmatrix} \quad (8)$$

UMM k=1, ..., Modes

Notice that the *driving point residue* $\mathbf{r}_{jj}(\mathbf{k})$ (where the row index(j) equals the column index(j)), plays an important role in this scaling process. The driving point residue for each mode(k) is required in order to use equation (8). These residues are obtained by making and curve fitting the corresponding driving point FRF measurement.

Triangular Measurement

All driving point FRFs occur along the *diagonal* of the transfer function matrix. A driving point FRF measurement is often difficult to make. Furthermore, because the contributions of all modes “sum together” in a driving point FRF, it is often more difficult to accurately curve fit than an *off-diagonal* measurement. Consequently, UMM shapes obtained from equation (8) is often error prone

As an alternative to the driving point FRF, three *off diagonal* FRFs can be made to provide the driving point UMM mode shape component \mathbf{u}_{jk} required in equation (8). The following relationship can be derived from equation (5),

$$\mathbf{u}_{jk} = \sqrt{\frac{\mathbf{r}_{jp}(\mathbf{k}) \mathbf{r}_{jq}(\mathbf{k})}{\mathbf{A}_k \mathbf{r}_{pq}(\mathbf{k})}} \quad \mathbf{k}=1, \dots, \text{Modes} \quad (9)$$

This expression for \mathbf{u}_{jk} can then be substituted into equation (8) to yield UMM mode shapes.

Equation (9) requires that three FRF measurements, involving three DOFs, DOF(p), DOF(q), and DOF(j), be made and curve fit to obtain the required residues. DOF(j) is the

reference (fixed) DOF for the \mathbf{j}^{th} column (or row) of the transfer function matrix. The two measurements \mathbf{H}_{jp} & \mathbf{H}_{jq} would normally be made along with the rest of the FRFs in the \mathbf{j}^{th} column (or row). One additional measurement \mathbf{H}_{pq} is required to satisfy equation (9). Since the measurements \mathbf{H}_{jp} , \mathbf{H}_{jq} , & \mathbf{H}_{pq} form a triangle in the transfer function matrix, they are called a *triangular measurement*.

An Example

To illustrate triangular measurement, Figure 1 depicts an FRF matrix for a structure with 4 DOFs, numbered 1 to 4. The circled measurements in column 3 depict a traditional modal test, where DOF 3 is the reference DOF. For triangular measurement, one extra measurement \mathbf{H}_{12} is also required.

The residues from \mathbf{H}_{12} , together with those from measurements \mathbf{H}_{13} & \mathbf{H}_{23} would be using in equation (9) to calculate the UMM mode shape component \mathbf{u}_{3k} for each mode(k). Then, \mathbf{u}_{3k} can be used together with residues from \mathbf{H}_{13} , \mathbf{H}_{23} & \mathbf{H}_{43} to obtain the UMM mode shape components \mathbf{u}_{1k} , \mathbf{u}_{2k} & \mathbf{u}_{4k} respectively, for each mode(k).

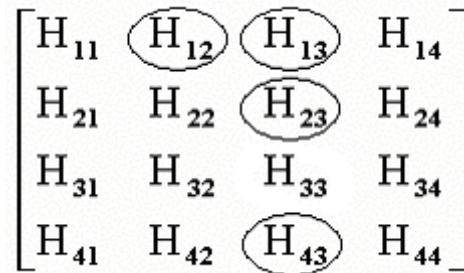

Figure 1. Triangular Measurement Example.

Notice that the driving point measurement \mathbf{H}_{33} was not needed in order to calculate the 4 UMM mode shape components. Therefore, the total number of required measurements remains the same (in this case 4), whether the driving point or the triangular measurement method is used for scaling.

OFF-DIAGONAL MEASUREMENTS

In addition to providing an alternative method for obtaining UMM mode shapes, Equation (9) also allows structures to be tested differently, by measuring a set only *off-diagonal* elements instead of a single row or column of the transfer

function matrix. This alternative testing method offers a significant advantage for testing larger structures.

For example, the 7 mile long San Mateo bridge cannot be tested by using a single reference and measuring one row or column of FRFs.

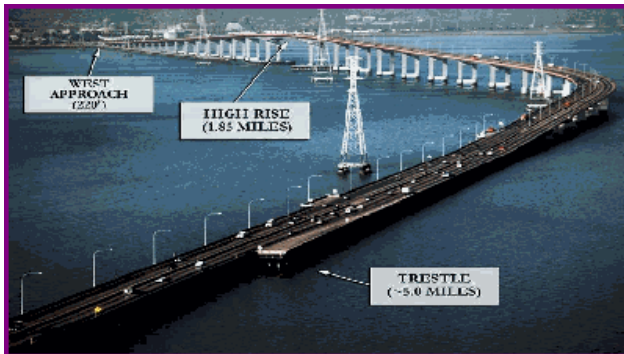

Figure 2. San Mateo Bridge.

Suppose that the off-diagonal elements shown in Figure 3 are measured instead of a column of FRFs.

UMM mode shapes can still be obtained from this set of measurements in a manner similar to the previous case.

$$\begin{bmatrix} H_{11} & H_{12} & H_{13} & H_{14} \\ H_{21} & H_{22} & H_{23} & H_{24} \\ H_{31} & H_{32} & H_{33} & H_{34} \\ H_{41} & H_{42} & H_{43} & H_{44} \end{bmatrix}$$

Figure 3. Off-Diagonal Measurements.

Residues from measurements H_{12} , H_{13} & H_{23} can be used three different ways in equation (9) to obtain the UMM mode shape components u_{1k} , u_{2k} & u_{3k} respectively, for each mode(k). Finally, mode shape component u_{4k} is calculated by using residues from H_{34} and mode shape component u_{3k} .

But the real advantage of this second example is the way in which the measurements are made. Each FRF is a two channel measurement, made between a pair of DOFs. In this case, the modal test could be laid out so that each pair of DOFs is “physically close” to one another.

For instance, an impact hammer, accelerometer, and 2-channel analyzer or data acquisition system could be used to move along a structure making measurements between pairs of neighboring DOFs. Any size of structure could be easily tested with this method.

By comparison, measuring one row or column of the transfer matrix requires that one DOF (either the accelerometer or the impact DOF) remain fixed as a reference. This can cause signal-to-noise as well as electrical cabling problems when testing large structures since some DOFs will be physically distant from the reference DOF.

ODS MEASUREMENTS

So far, we have only addressed mode shape scaling when FRFs are measured. Experimental mode shapes are most commonly obtained by curve fitting a set of FRF measurements. However, an FRF measurement requires that *all of the excitation forces causing a response be simultaneously acquired with the response.*

Measuring all of the excitation forces can be difficult, if not impossible in many situations. FRFs cannot be measured on operating machinery or equipment where internally generated forces, acoustic excitation, and other forms of excitation are unmeasurable.

Operating Deflection Shape

On the other hand, one or more vibration responses can always be measured, no matter what forces are causing the vibration. When *two or more* response measurements are made on a machine or structure, this is called an Operating Deflection Shape (ODS), or simply a Deflection Shape.

Like a mode shape, an ODS is defined with a *magnitude & phase* of the vibration response at each measurement point. In order to define a valid ODS vector, the *magnitude & phase* of each response *relative to all others* is required at each of the response measurement points.

Time Domain ODS Measurements

In a set of time domain ODS measurements, relative magnitude & phase are implicitly assumed. This requires that *all responses are simultaneously acquired*, or at least measured under conditions when a repeatable event can be captured using a trigger [5].

Simultaneous acquisition of all responses requires a multi-channel acquisition system that can simultaneously acquire all of the response signals. This requires lots of transducers and signal conditioning equipment, which is expensive.

Frequency Domain ODS Measurements

The advantage of making a set of frequency domain measurements is that relative magnitudes & phases of two or more response measurements can be assured, and *simultaneously acquisition* is only required using *as few as 2-channels at a time.*

It will also be assumed that the machine or structure is vibrating in a *stationary* manner [5], [8], [9]. If this is not the case, then further signal processing may be required [6].

Measurement Sets

When the data acquisition system does not have enough channels to simultaneously acquire all of the channels, then data must be acquired in multiple *measurement sets* [9]. To insure proper relative phases between multiple roving (different) responses acquired with multiple measurement sets, at least one channel must be used as a reference (fixed) channel, and it must be measured in all measurement sets.

To preserve the correct relative phase among all responses, a Cross Power Spectrum (XPS) measurement must be made between each roving response and a reference response.

In order to see how this measurement can be used to obtain mode shapes, the relationship between the response Auto Power Spectrum (APS) and the FRF is considered first.

Relationship Between the Response APS & FRF

An FRF is defined as the Fourier spectrum of a vibration response divided by the Fourier spectrum of the force that caused the response,

$$\mathbf{H}(\omega) = \frac{\mathbf{X}(\omega)}{\mathbf{F}(\omega)} \quad (10)$$

where:

$\mathbf{X}(\omega)$ = Fourier spectrum of response.

$\mathbf{F}(\omega)$ = Fourier spectrum of excitation force.

ω = frequency variable.

The FRF is a 2-channel measurement, and requires that both the force and the response signals be *simultaneously acquired*. The magnitude squared of the FRF can be written as,

$$|\mathbf{H}(\omega)|^2 = \frac{\mathbf{X}(\omega) \mathbf{X}(\omega)^*}{\mathbf{F}(\omega) \mathbf{F}(\omega)^*} \quad (11)$$

where:

$\mathbf{X}(\omega) \mathbf{X}(\omega)^*$ = APS of the response.

$\mathbf{F}(\omega) \mathbf{F}(\omega)^*$ = APS of the excitation force.

* - denotes complex conjugate.

Because the response spectrum is divided by the force spectrum, we know that any peaks in the FRF must be due to modes (or resonances) of the structure. Resonance peaks will also appear at the same frequencies in the APS of the response. Equation (11) also leads to the following result.

Flat Force Spectrum Assumption: *If the APS of the excitation force is assumed to be “relatively flat” over the frequency range of measurement, then any peaks in the response APS are due to modes of the structure.*

Response APS Matrix

Equation (11) can be generalized to a matrix of FRF products involving multiple roving & reference responses. The diagonal elements of this matrix are the same as equation (11) for each response, while the off-diagonal elements are complex valued,

$$[\mathbf{H}_X \mathbf{H}_Y(\omega)] = \frac{\{\mathbf{X}(\omega)\}\{\mathbf{Y}(\omega)\}^T}{\mathbf{F}(\omega) \mathbf{F}(\omega)^*} \approx \{\mathbf{X}(\omega)\}\{\mathbf{Y}(\omega)\}^T \quad (12)$$

where:

$\{\mathbf{X}(\omega)\}$ = vector of Fourier spectra of a roving responses (**Roving DOFs - vector**).

$\{\mathbf{Y}(\omega)\}$ = vector of Fourier spectra of reference responses (**Reference DOFs - vector**).

\mathbf{T} – denotes the conjugate transpose.

$[\mathbf{H}_X \mathbf{H}_Y(\omega)]$ = matrix of FRF products.
(**Roving DOFs by Reference DOFs**)

If the **Flat Force Spectrum Assumption** is again made, then the above matrix is proportional to a matrix of XPS's formed between each roving and each reference response. This matrix is simply referred to as the Response XPS Matrix,

$$[\mathbf{XPS}(\omega)] = \{\mathbf{X}(\omega)\}\{\mathbf{Y}(\omega)\}^T \quad (13)$$

where:

$[\mathbf{XPS}(\omega)]$ = Response XPS Matrix.
(**Roving DOFs by Reference DOFs**)

Because of the Flat Force Spectrum Assumption, resonance peaks that would appear in the FRFs due to modes will also appear at the same frequencies in each element of the Response XPS Matrix. Also, the values of a column of this matrix at any frequency is an ODS.

Operating Mode Shapes From a Column of the Response XPS Matrix.

Operating mode shapes can be obtained by curve fitting a parametric model of an FRF to the square root (or RMS) of elements from a column of $[\mathbf{XPS}(\omega)]$ [6]. Since forces are not measured, these operating mode shapes *are not* UMM mode shapes. Furthermore, if it is assumed that FRF measurements cannot be made, the operating mode shapes cannot be scaled to UMM mode shapes by using the previously described methods. Two new scaling methods are introduced below which don't rely on FRF measurements.

REVIEW OF THE SDM METHOD

The SDM (or eigenvalue modification) method uses a set of UMM mode shapes from an unmodified structure, together with one or more finite element representations of a structural modification (e.g. mass, stiffener, or tuned absorber addition) to calculate a new set of modes for the modified structure [10]. This process is depicted in Figure 4.

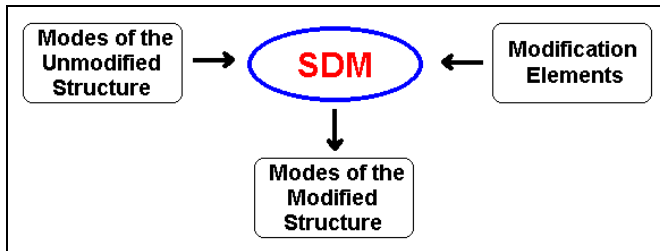

Figure 4. SDM Procedure.

Since the SDM procedure *requires* a set of UMM mode shapes for the unmodified structure, if the mode shapes are not scaled properly, the intended modification will yield incorrect modal shapes for the modified structure. This fact is utilized in a search procedure that finds an optimal scale factor (or set of scale factors) so that SDM yields correct answers from a set of operating mode shapes.

SCALE FACTOR SEARCH METHOD

Suppose that a specific modification (such as a mass addition) to a certain machine or structure is known to yield a new set of modal frequencies. These new frequencies could be determined experimentally by measuring a single XPS under operating conditions and curve fitting it.

This known modification, together with SDM and an optimal search algorithm, can be used to scale a set of operating mode shapes to UMM mode shapes.

It is assumed that in a given set of operating mode shapes, each is correct in “*shape*” but will differ from its corresponding UMM mode shape by a multiplicative scale factor. To determine an optimum set of scale factors, the SDM algorithm is used to calculate modified mode shapes, and a search procedure is used to iterate toward a set of scale factors which yield the correct modes for the modified structure.

In general, the objective function to be minimized can be written as,

$$J = \text{MIN} \left[\sum_{K=1}^{\text{Modes}} (F_{\text{Known}}(\mathbf{k}) - F_{\text{SDM}}(\mathbf{k}))^2 \right] \quad (14)$$

where:

$F_{\text{Known}}(\mathbf{k})$ = known modal parameter (frequency, damping, or mode shape component).

$F_{\text{SDM}}(\mathbf{k})$ = modal parameter predicted by SDM.

J = Objective function.

Finding a Single Scale Factor

The simplest case is to assume that the excitation force spectrum is not only flat but has the same value for all frequencies. This means that all of the operating mode shapes differ from their corresponding UMM mode shapes by a single scale factor. The search problem can then be stated in the following manner,

Single Scale Factor Search Problem: Find a single scale factor (S_f), which when multiplied by a set of operating mode shapes,

$$[S_f \{u_1\} S_f \{u_2\} \dots S_f \{u_m\}] = \text{operating mode shape matrix (DOFs by Modes)}$$

and used together with the SDM method, minimizes the objective function (J) in equation (14).

SCALING WITH A KNOWN MODIFICATION

The Single Scale Factor Search Problem can be further simplified by using only modal frequencies in the objective function (J). Mass modifications are easy to make to most real structures, and the new modal frequencies are relatively easy to determine experimentally. Therefore, the objective function (J) becomes merely a summation of the squared differences between the known modal frequencies of the modified structure, and those calculated by the SDM method.

Illustrative Example: To illustrate the UMM scaling procedure using a known modification, consider the lumped parameter model shown in Figure 5. This structure has two modes, an “in-phase” mode as **2.82 Hz**, and an “out-of-phase” mode at **8.98 Hz**, as shown in Figure 6.

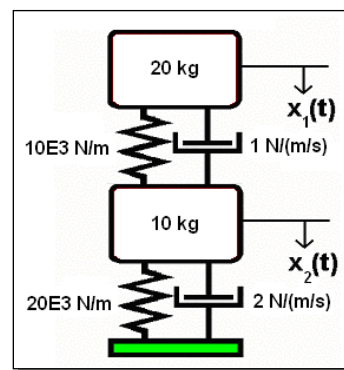

Figure 5. 2-DOF Structure.

Error Due To Un-scaled Mode Shapes

To test the Known Modification search method, a 1 Kg mass was added to each mass. Using UMM shapes, this modification changed the model frequencies to **2.75 Hz** and **8.58 Hz**.

To investigate the effects of incorrectly scaled shapes on the objective function (**J**), un-scaled mode shapes were *simulated* by multiplying the UMM shapes by a range of scale factors (from 1E-5 to 1E+5), listed in the first column of Table 1. Then the known modification (two 1 Kg masses) was made using each set of un-scaled shapes.

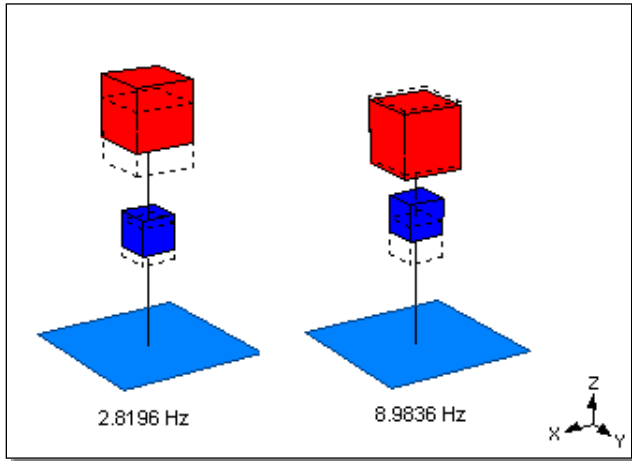

Figure 6. Modes of the 2 DOF Structure.

The new modal frequencies and objective function (**J**) values are also shown in Table 1. These results show that as the un-scaled shapes become much less than the UMM shapes (Scale By's << 1), the modification has no effect on the modal frequencies and **J** "flattens out" at **0.165**.

Also, as the un-scaled shapes become much greater in value than the UMM shapes (Scale By's >> 1), the modification drives the modal frequencies toward **0 Hz**, and again **J** "flattens out" at **81.179**.

This behavior indicates that a range of scale factor values can be found between the extremes where **J** "flattens out". For the 2-DOF structure, the range is **0.1 to 10000**. In fact, correct scale factors (inverses of the scale by's listed in Table 1) were found by our Known Modification search method for all cases between **0.001 & 100,000!**

SCALING BASED ON A MODIFICATION ROUND TRIP

One of the unique characteristics of the SDM algorithm is that it works equally well when modifications are *subtracted* from a structure. This capability can be used to perform a modification "round trip" to a structure.

In a modification round trip, SDM is used twice; first to add modification elements to a structure and obtain new mode shapes, and then to subtract the same modification elements from the modified structure and recover the original mode shapes.

If the original mode shapes are UMM mode shapes, then the modification round trip should return the original UMM shapes. In the original modes are operating mode shapes (not properly scaled), the round trip will yield different modal parameters.

Following a modification round trip, the objective function (**J**) is calculated as a summation of the squared differences between the original modal parameters and those calculated by the modification round trip.

Shapes Scaled By	Mode 1 frequency	Mode 2 frequency	J
0.00001	2.82	8.98	0.165
0.0001	2.82	8.98	0.165
0.001	2.82	8.98	0.165
0.01	2.82	8.98	0.165
0.1	2.82	8.98	0.165
0.25	2.81	8.96	0.148
0.50	2.80	8.88	0.093
0.75	2.78	8.75	0.030
1.0	2.75	8.58	0.0
2.5	2.44	7.10	2.287
5.0	1.84	4.89	14.444
7.5	1.41	3.58	26.796
10	1.12	2.79	36.181
100	0.122	0.294	75.564
1000	0.0122	0.0294	80.607
10,000	0.00128	0.00294	81.179
100,000	0.000122	0.000294	81.179

Table 1. Modifications Using Un-Scaled Shapes.

For the 2-DOF Structure model shown in Figure 3 and the un-scaled shape cases shown in Table 1, the Modification Round Trip algorithm converged on the correct scale factors for all cases between **0.5 & 1000**.

CONCLUSIONS

Mode shape scaling is important if a set of experimental mode shapes is to be used for further modeling and simula-

tion studies. If the mode shapes are obtained from operating data, they will not be properly scaled.

As background for the new scaling methods introduced here, two traditional UMM scaling methods (which rely on FRF measurements) were reviewed first. However, these methods cannot be used in situations where the excitation forces cannot be measured, and consequently FRFs cannot be calculated.

Two new scaling methods, which combine the SDM method with an optimal search algorithm were introduced. The first method (Known Modification) requires that the modal parameters of a known structural modification be measured. A simple mass addition is relatively straightforward to carry out in most operating environments, and this is sufficient to cause the mode to change. The modal frequencies of the modified structure are a minimum requirement, and they could be obtained from a single auto APS measurement.

The second scaling method (Modification Round Trip) is strictly computational, and relies on the fact that a modification round trip using SDM will return the original UMM mode shapes, if they are properly scaled. Otherwise, modes with different modal parameters are returned.

Both of these scaling methods rely on an iterative optimal search algorithm, and no proof of convergence to a unique solution was given. The types, amounts, and physical locations of the modifications used will clearly influence the convergence performance. It is conceivable that a solution may be difficult or impossible to find in many situations.

Although the examples given only involved a single scale factor for all mode shapes, both methods have been extended to a multi-dimensional search for a scale factor for each mode shape. A good strategy is to search for a single scale factor first, apply it to all shapes, and then perform a multi-dimensional search for each mode shape scale factor.

Prior to using either scaling method, operating mode shapes should be scaled by multiplying them by the *inverse of the square root of the estimated mass* of the structure. This will scale them into the "vicinity" of the correct UMM values, and improve the convergence of the search methods.

Although more research is required to further validate this approach to mode shape scaling, it has been shown to work well for simple cases.

REFERENCES

1. Potter, R. and Richardson, M. "Mass, Stiffness and Damping Matrices from Measured Modal Parameters" I.S.A. International Instrumentation - Automation Conference, New York, New York, October 1974. (Vibrant Tech. Paper No. 3 www.vibetech.com)
2. Richardson, M. "Derivation of Mass, Stiffness and Damping Parameters from Experimental Data" Hewlett Packard Co. Internal Paper, June 1977. (Vibrant Tech. Paper No. 30, www.vibetech.com)
3. Richardson, M. "Modal Mass, Stiffness and Damping" Vibrant Tech. Paper No. 31, www.vibetech.com, January, 2000.
4. Richardson, M. "Measurement and Analysis of the Dynamics of Mechanical Structures" Hewlett-Packard Conference for Automotive and Related Industries, Detroit, Michigan, October, 1978. (Vibrant Tech. Paper No. 4 www.vibetech.com)
5. Richardson, M. "Is It A Mode Shape Or An Operating Deflection Shape?" Sound and Vibration Magazine, February, 1997. (Vibrant Tech. Paper No. 10 www.vibetech.com)
6. Vold, H. Schwarz, B. & Richardson, M. "Measuring Operating Deflection Shapes Under Non-Stationary Conditions" International Modal Analysis Conf. (IMAC XXI), February 7-10. 2000. (Vibrant Tech. Paper No. 32 www.vibetech.com)
7. Richardson, M. "Modal Parameter Estimation From Operating Data" Sound and Vibration Magazine, November 2002. .
8. Schwarz, B. & Richardson, M. "Modal Parameter Estimation From Ambient Response Data" International Modal Analysis Conf. (IMAC XXII), February 5-8. 2001. (Vibrant Tech. Paper No. 33 www.vibetech.com)
9. Schwarz, B. & Richardson, M. "Post-Processing Ambient and Forced Bridge Data to Obtain Modal Parameters" International Modal Analysis Conf. (IMAC XXII), February 5-8. 2001. (Vibrant Tech. Paper No. 34 www.vibetech.com)
10. Formenti, D. & Welaratna, S. "Structural Dynamics Modification - An Extension to Modal Analysis" SAE Paper No. 811043, Oct. 1980